



VK-SBL PRO PLUS™

CONVERSION KIT

INSTALLATION INSTRUCTIONS

BOM PARTS LIST:

1. Barrel Sleeve 2.0
2. PepperBall 60 Round Hopper
3. PepperBall Red Dot
4. Front Grip- 5. Free Float Handguard
- 6. PepperBall VKS Hopper Adapter
- 7. VKS 10.5" Smooth Bore Barrel
- 8. PepperBall 15 cu in PRO Tank
- 9. Picatinny Rail-Black x1
- 10. Picatinny Rail-Yellow x2
- 11. Rail Cover-Yellow

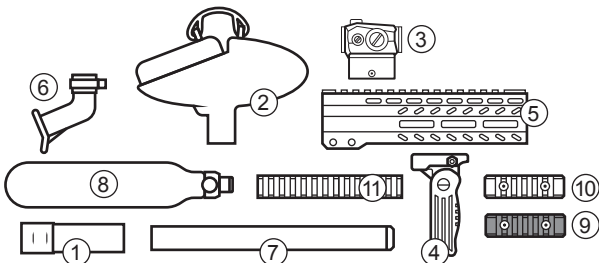

TOOLS NEEDED:

- 1 ¼" Wrench or Equivalent
- 3 mm Hex Wrench
- 3/32" Hex Wrench

STEP 1

Disengage air at charging handle. Remove buttstock, tank, barrel and barrel spring. Stabilize upper receiver on bench or in non-marring vise. Remove 4 screws attaching quad rail to barrel sleeve using 3 mm hex wrench and remove quad rail.

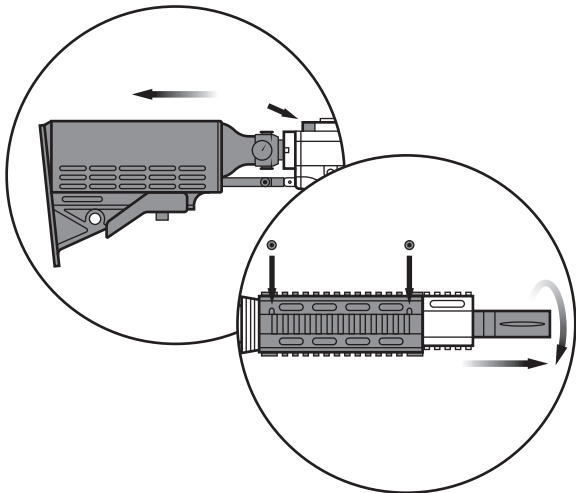

STEP 2

Using armorers wrench, break loose the delta ring, unthread and remove barrel sleeve.

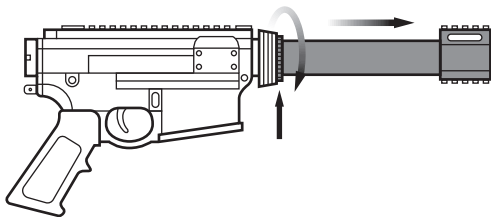

STEP 3

Thread on barrel sleeve, aligning threaded end of sleeve with threaded end of upper receiver. Using a 1¼" open end wrench or adjustable wrench that will open wide enough, seat barrel sleeve firmly onto upper receiver.

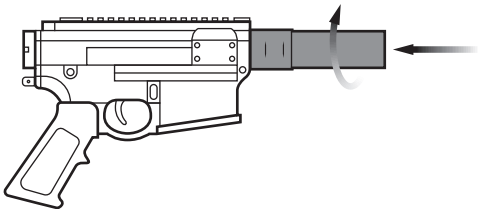

STEP 4

Install black picatinny rail section onto bottom of handguard bridging first and second slot, with center post in second slot. Ensure rail section seats fully against handguard. Ensure rail cams rotate 90° and tighten with 3 mm hex wrench. Colored rail sections install on left and right side in same location. Install front grip onto rail, centering grip on rail.

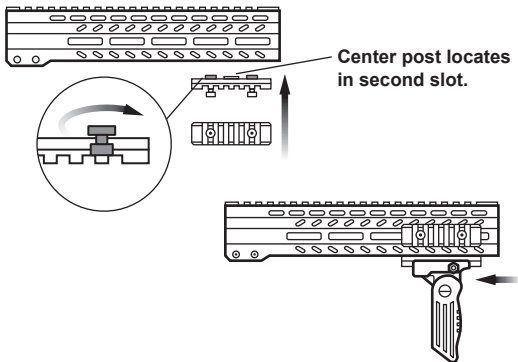

STEP 5

Slide the handguard over the barrel sleeve until fully seated. Ensure top rail on handguard is aligned with rail on upper receiver. Insert the screws into the screw holes in the handguard and secure using a 3 mm hex wrench. Tighten screws incrementally 3 times, moving back and forth to ensure handguard is evenly secured.

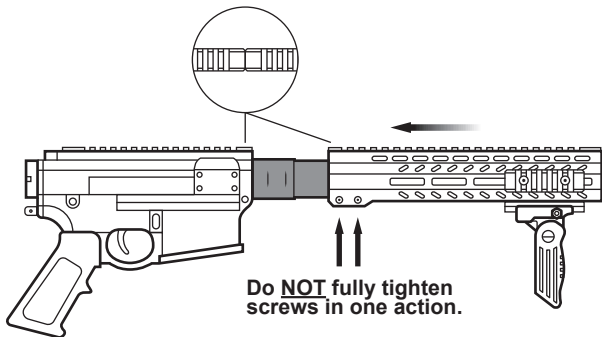

STEP 6

Install your new 15 cu in PRO tank, buttstock, barrel spring, and 10.5" smooth bore barrel.

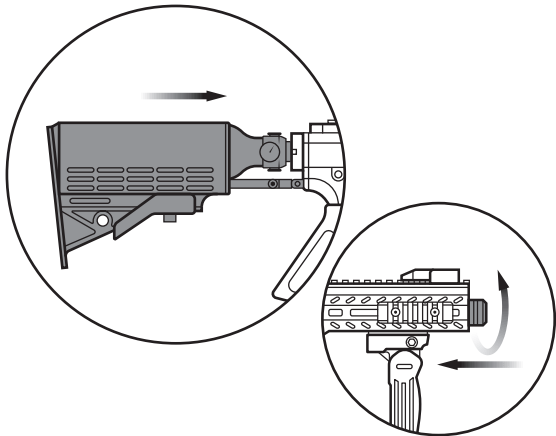

OPTIONAL VKS™ HOPPER ADAPTER INSTALLATION

STEP 1

To install the VKS™ hopper adapter, please locate the hopper adapter plate. Using a 3/32" hex wrench, remove screws by turning counter clockwise. Once hopper adapter plate has been removed, clean the surface of the launcher body.

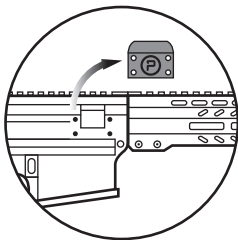
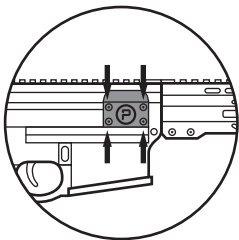

STEP 2

Install the hopper adapter, and screws. Using a 3/32" hex wrench, tighten the screws in increments, making sure that all screws are tightened equally. **DO NOT OVER TIGHTEN SCREWS. THIS COULD RESULT IN THE HOPPER ADAPTER BASE BREAKING.**

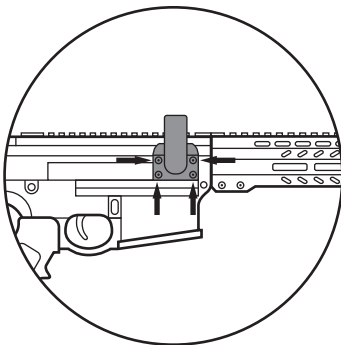

RED DOT WITH RISER INSTALLATION

STEP 1

Using the provided star bit wrench, remove the screws from low mounting rail.

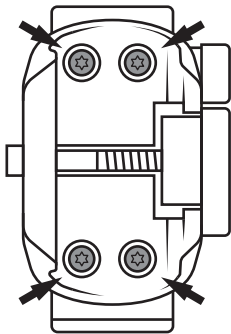

STEP 2

Place screws in the riser screw holes.

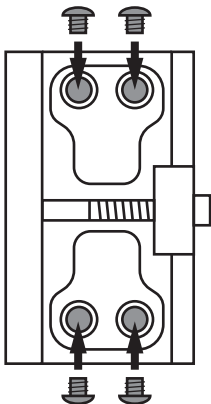

STEP 3

Line up the riser, and red dot. Turning clockwise, tighten screws evenly.

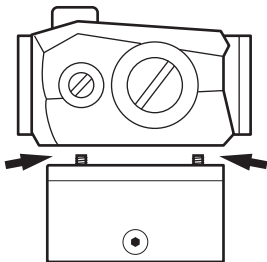

STEP 4

Using a 3 mm hex wrench, loosen the riser, and slide onto the rail of your VK-SBL PRO PLUS™. Tighten the screw by turning clockwise.

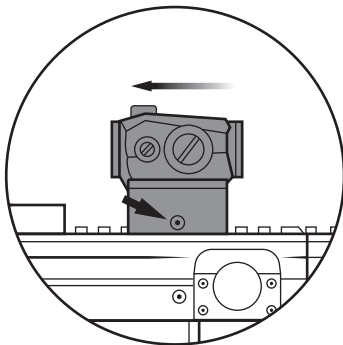



PepperBall® A Division of United Tactical Systems, LLC
28101 Ballard Drive, Suite F
Lake Forest, IL 60045
PepperBall.com | (888) 874-3491

010225